

Improving Software Security via Runtime Instruction-Level Taint Checking

Jingfei Kong, Cliff C. Zou and Huiyang Zhou



School of Electrical Engineering and Computer Science
University of Central Florida



Outline

- Motivation
- Design
- Experiments
- Applications
- Conclusion



Low-level Memory Vulnerabilities

- Program defects
 - Unsafe languages (C / C++) do not check/restrict memory accesses
 - Buffer Overflow, Heap Corruption, Format String ...
 - Result in many kinds of exploits - major threats to the internet
- No Silver bullet so far
 - Hard to find and fix defects in advance
 - Exploit-focused solutions can always be bypassed.
 - Defect-focused solutions are costly



Tainting Architectures

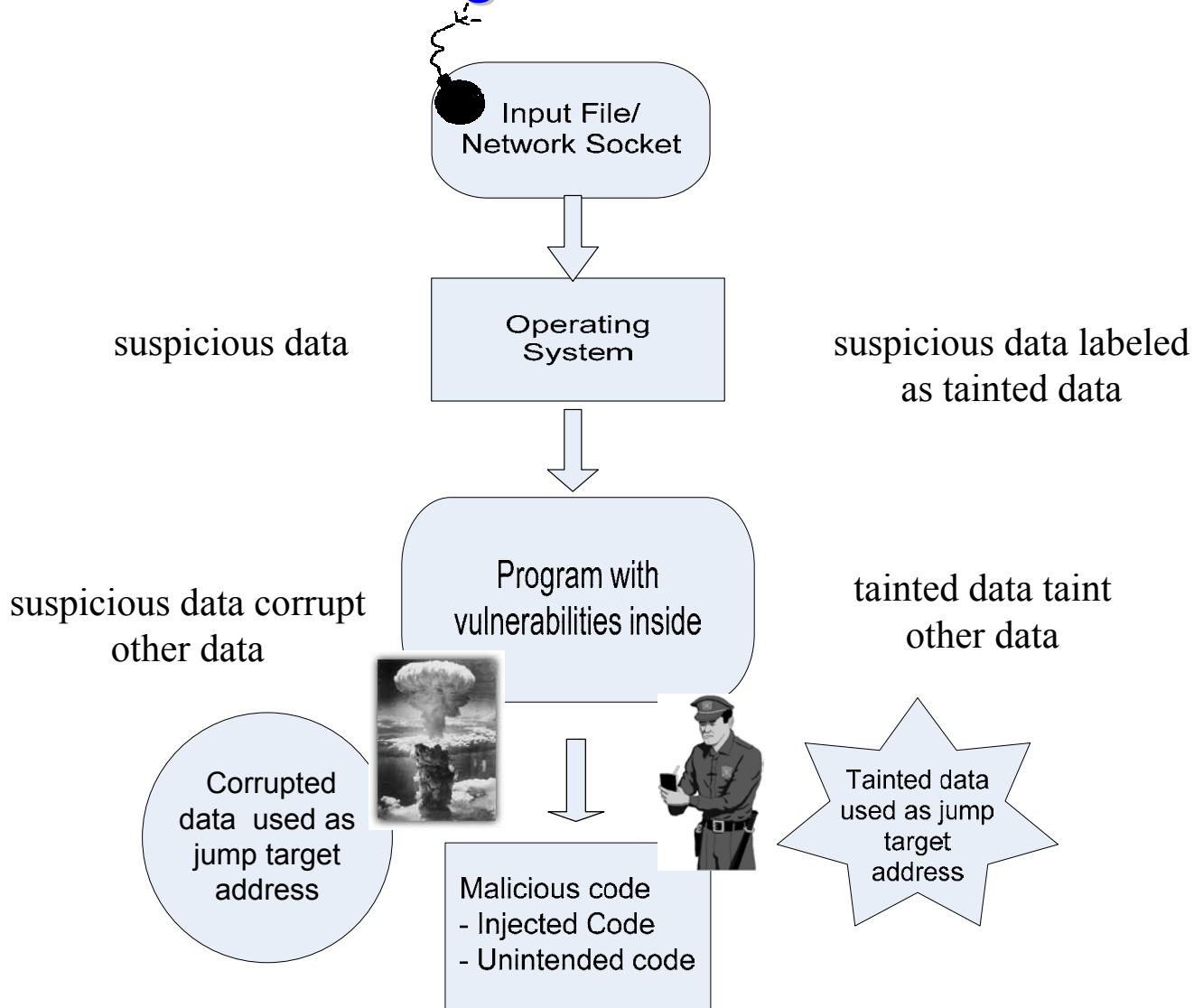



Non-control Data Attacks and Pointer Taintedness Checking

- Security-Critical Non-Control Data (Chen' Usenix Security 2005)
 - Configuration data
 - User input
 - User identity data
 - Decision-making data
 - Conclusion: as effective as the well-known control data attacks
- Pointer Taintedness Checking (Chen' DSN 2005)
 - Tainted data are not allowed to be used as pointers
 - Untaint tainted data only when *compared* with untainted value



Problems with Pointer Taintedness Checking

There are some attacks which do not use tainted pointers

```
void information_leakage()
{
    unsigned int limit = 50;
    char buf[20];
    int p[50];
    unsigned int i;

    //buffer overflow!
    A: scanf("%s", buf);
    B: for (i=0; i<limit; i++)
        printf(" %x ", *(p+i));
}
```



Another Example

```
*void leak() {  
    int secret_key;  
    char buf[12];  
    A: recv(s,buf,12,0);  
    B: printf(buf); //format string!  
}
```

*From Chen' DSN 2005



A New Format String Attack

This new format string attack can write arbitrary *untainted* values (Dalton' WDDD 2006), even with arbitrary untainted target addresses

- A typical format string attack
 - The format string supplies the target address directly
 - The format string also contains constant widths to specify the value to be written
- The new attack
 - Use "*" specifier to get field widths from *untainted values* in the *stack* to construct arbitrary untainted values



Our Idea: Instruction-Level Taint Checking

- Instruction-level -- a generic form of taint checking
 - Cover more data taint checking than previous ones
 - Minor changes to the existing taintedness tracking architectures
 - Provide a higher degree of security protection
- Taintless-Instruction
 - An instruction does not deal with tainted data
- Tainted-Instruction
 - An instruction deals with tainted data



Outline

- Motivation
- Design
- Experiments
- Applications
- Conclusion



Our Design

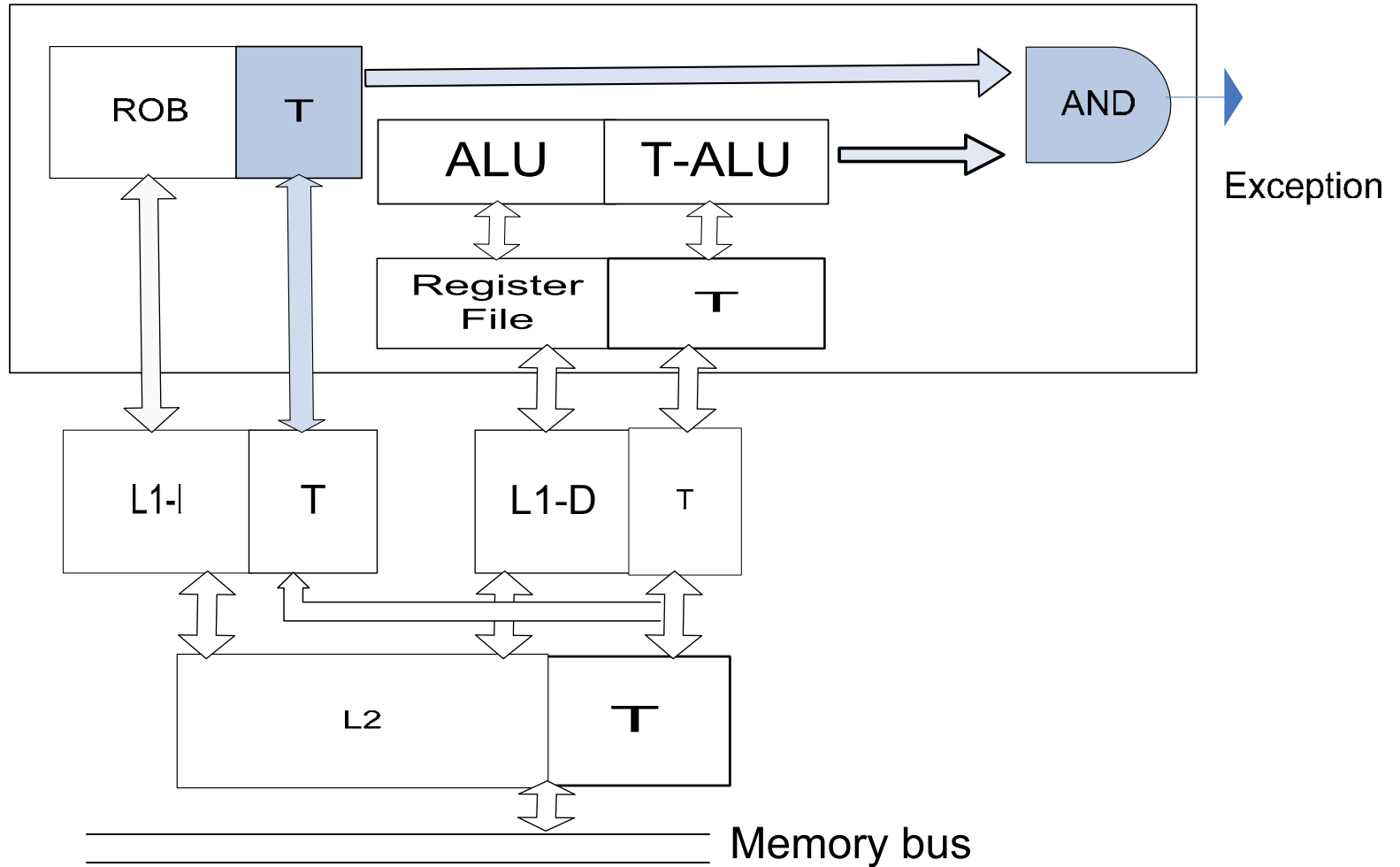



Instruction-Level Taint Checking

- Taintless-Instruction Profile collection
 - Manual annotation
 - Static analysis
 - Dynamic training
- Taint checking is carried out in four steps at runtime
 - Load the collected Taintless-Instruction profile
 - Tag data from suspicious input channels as tainted
 - Track taintedness propagation through execution
 - Raise an alarm when a Taintless-Instruction encounters some tainted operand



Outline

- Motivation
- Design
- Experiments
- Applications
- Conclusion



Experimental Methodology

- SimpleScalar processor simulator with the PISA instruction set
 - Byte-granularity taintedness tracking
 - Taint data from I/O system calls such as READ, RECV, etc.
 - Bitwise OR of the taintedness bits from source operands
 - Similar to the rules used in Chen' DSN 2005



Preliminary Results from SPEC CPU2000

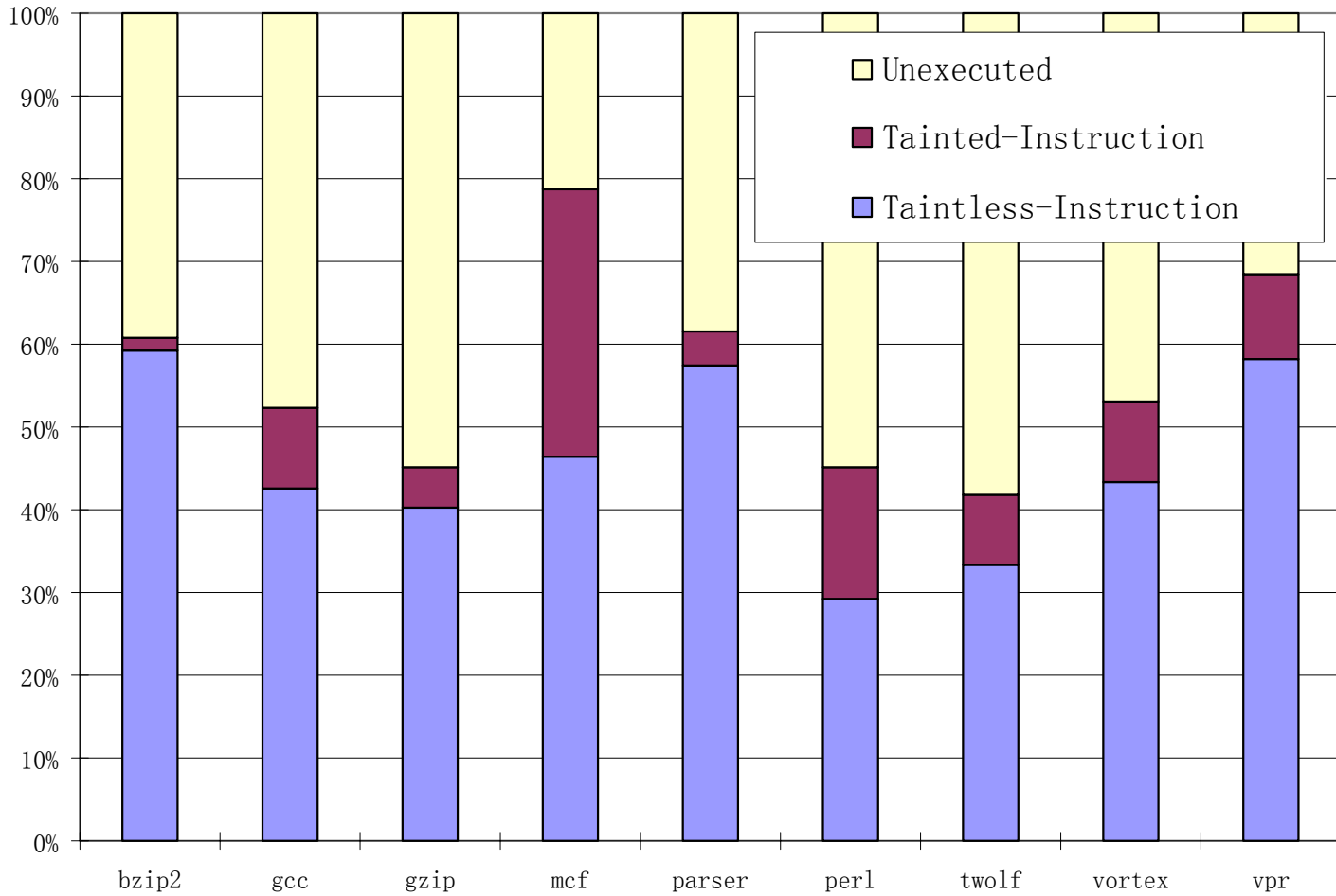



Outline

- Motivation
- Design
- Experiments
- Applications
- Conclusion



Canary Protection Schemes Against Buffer Overflow

```
/* declaration part of local variables */  
    volatile int guard;  
  
/* the entry point */  
    guard = guard_value;  
  
/* the exit point */  
    if (guard != guard_value) {  
        /* output error log */  
        /* halt execution */  
    }
```

ProPolice

<http://www.trl.ibm.com/projects/security/ssp/>



Buffer Overflow

```

void vuln_stack_function_ptr(int choice)
    volatile unsigned int pad_end = 0;
    long stack_buffer[BUFSIZE];
    volatile unsigned int pad_begin = 0;

    void (*stack_function_pointer)(void);
    ...
    memcpy(stack_buffer,
           overflow_buffer, overflow+4);
    pad_begin++;
    pad_end++;
    (void)(*stack_function_pointer)();

```

pad_begin++;
pad_end++;

Untainted data

Taintless Instructions

```

jal    00404e80 <memcpy>
lw     $v0[2],32($sp[29])
addiu  $v0[2],$v0[2],1
sw     $v0[2],32($sp[29])
lw     $v0[2],32($sp[29])
lw     $v0[2],104($sp[29])
addiu  $v0[2],$v0[2],1
sw     $v0[2],104($sp[29])
lw     $v0[2],104($sp[29])
lw     $v0[2],108($sp[29])
jalr   $ra[31],$v0[2]

```

Code from the testbed of twenty buffer overflow attacks by John Wilander' NDSS 2003



Comparison

- Our improvements
 - Fewer number of instructions to be executed
 - More secure since the guard values do not have to remain secret



Format String

```
int
DEFUN(vfprintf, (s, format, args),
  register FILE *s AND CONST char
  *format AND va_list args)
```

```
{
/* Pointer into the format string. */
register CONST char *f;
...
f = format;
```

```
f = format;
```

The Devil enters here

```
A: while (*f != '\0')
```

```
{
```

```
B: ...
```

Mark them as Taintless-Instructions to catch format string attacks

```
addu $t0[8], $zero[0], $s0[16]
```

```
j A
```

```
B: ...
```

```
...
```

```
A: lb $v0[2], 0($t0[8])
```

```
lbu $v1[3], 0($t0[8])
```

```
bne $v0[2], $zero[0], B
```



Conclusion

- A new generic instruction-level taint checking architecture
 - Minor changes to the existing taintedness tracking architectures
 - Minor performance overhead
 - Compatible with existing ISAs
 - Provide a higher degree of security protection



Ongoing Work

- Experiments on real applications
 - Instruction-Level program taintedness behavior
 - Collection of Taintless-Instructions profile
 - Static analysis
 - Dynamic training
 - Evaluation of taint checking schemes



Thank you!

Questions?