

Errata to Approaching Quantum Computing

June 12, 2012

Preface

Page IX, line 3. The sentence starting with:

“There are $k^O - 102$ equations ... is a very large number.”

should read:

“There are $k > 10^2$ equations in these series of lectures and $2^{100} = 2^{10 \times 10} \approx 10^{3 \times 10} = 10^{30}$ is a very large number.”

Page IX, line 30. The last name on this line:

“Veron”

should read:

“Vernon”

Page IX, line 34. The formulation:

“at UCF during the Spring and Fall 2003 semesters have signaled”

should read:

“at UCF since the Spring of 2003 have signaled”

Notations

Page XII, line 26. Entry δ_{ij} :

“Kronecker’s”

should read:

“Kronecker”

Page XII, line 34. Entry $|\psi_i\rangle$

“The state of a quantum system.”

should read:

“The state vector of a quantum system (Dirac’s notation).”

Page XIII, line 7. Entry G_{CNOT} :

“The matrix of the controlled-NOT, (CNOT), a two-qubit gate:”

should read:

“The matrix of the controlled-NOT, (CNOT), two-qubit gate:”

Page XIV, line 8. Entry $V_k(F)$:

“Vector space of k tuples over the field F .”

should read:

“Vector space of k -tuples over the field F .”

Chapter 1

Page 2, line 18.

“The laws of physics, and, in particular,”
should read:

“The laws of physics and, in particular,”

Page 5, line 12.

“theory are concerned with the transmission and processing of quantum states”
should read:

“theory are concerned with the transformation, storage, and transport of quantum states”

Page 8, line 19. The formulation:

“in an intimately fused state”

should read:

“in an intimately correlated state”

Page 15, line 22. The formulation:

“Assume that we have a quantum particle with two properties”

should read:

“Assume that we have some quantum particles with two properties”

Page 16, line 10-11. The formulation:

“on the vectors forming the basis of a coordinate system.”

should read:

“on the basis of a coordinate system.”

Page 21, line 12 from the bottom. The formulation:

“in the modulus of the complex number”

should read:

“is the square of the modulus of the complex number”

Page 25, beginning of line 24. The formulation:

“occurred.”

should read:

“occurred before event \mathcal{A} .”

Page 34, the footnote. The formulation:

“absorbs and emits radiation”

should read:

“absorbs and emits perfectly radiation.”

Page 35, last line. The formulation:

“Eckert-Macaulay”

should read:

“Eckert-Mauchly”

Page 39, Table 1.2., the entry for 1945 The name:

“Macauly”
should read:
“Mauchly”

Page 40, Table 1.2., the entry for 1982 The name:
“Peter Benioff”
should read:
“Paul Benioff”

Page 40, line 7 of the text The formulation:
“the measurement process alters the state of a quantum system”
should read:
“the measurement process alters the states of a quantum system”

Page 40, line 7 of the text The name:
“Omnes”
should read:
“Omnès”

Page 40, line 10 of the text The formulation:
“plain empirism”
should read:
“plain empiricism”

Page 40, last line of the text The name:
“J. M. Gelfand”
should read:
“I. M. Gelfand”

Chapter 2

Page 43, line 8. The formulation:

“model of the physical world”

should read:

“model of the microscopic world”

Page 43, line 9. The formulation:

“classical mechanics fails to explain.”

should read:

“classical physics fails to explain.”

Page 43, line 12. The formulation:

“We first introduce the basic definitions”

should read:

“We first review the basic definitions”

Page 45, line 22.

“Given $c', c'_1, c'_2 \dots c'_n \in F$ the following ...”

should read

“Given $c', c'_1, c'_2 \dots c'_m \in F$ the following ...”

Page 45, line 24

$$c'(c'_1\alpha_1 + c'_2\alpha_2 + \dots + c'_m\alpha_m) = (c'c'_1)\alpha_1 + (c'c'_2)\alpha_2 + \dots + (c'c'_m)\alpha_m$$

should read:

$$c'(c'_1\alpha_1 + c'_2\alpha_2 + \dots + c'_m\alpha_m) = (c'c'_1)\alpha_1 + (c'c'_2)\alpha_2 + \dots + (c'c'_m)\alpha_m$$

Page 47, line 19.

“... the function $A(\alpha, \beta)$...”

should read

“... the function $A(\alpha; \beta)$...”

Page 49, line 19. After the last equation, at the end of the line:

“.”

should read:

“.”

Page 49, after line 19 add:

“a polynomial of order n , in the indeterminate λ for an $n \times n$ matrix A .

The *characteristic equation of matrix A* is:

$$|A - \lambda I| = 0$$

with roots λ_i , also called the *characteristic roots of the matrix A* .”

Page 50, bottom of the page, last sentence.

“Recall that $c = (\alpha, \beta)$ is a complex number,”

should read

“Recall that $(\alpha, \beta) = c$, a complex number,”

Page 53, line 16. The footnote 3, for “Cauchy sequence”:

“A sequence $\{a_n\}$ is Cauchy if for any $\epsilon > 0$, there exists N so that $\| a_k - a_r \| < \epsilon$ for $k, r > N$.”

should read:

“A sequence $\{a_n\}$ is called a *Cauchy sequence* if for any $\epsilon > 0$, there exists N so that $| a_k - a_r | < \epsilon$ for $k, r > N$. The terms of the sequence become arbitrarily close to each other.”

Page 56, line 6. The expression:

$$\langle \psi | \psi \rangle = \begin{cases} = 0 & \text{if } | \psi \rangle = 0 \\ > 0 & \text{otherwise} \end{cases}$$

should read:

$$\langle \psi | \psi \rangle \begin{cases} = 0 & \text{if } | \psi \rangle = 0 \\ > 0 & \text{otherwise} \end{cases}$$

Page 58, first line.

“Schwartz inequality”

should read:

“Schwarz inequality”

Page 62. The expression on line 4:

$$\langle \Psi_a | \quad \longrightarrow \quad \alpha_0^* \langle 0 | + \alpha_1^* \langle 1 | + \alpha_2^* \langle 2 | + \alpha_3^* \langle 3 | .$$

should read:

$$\langle \Psi_a | \quad \mapsto \quad \alpha_0^* \langle 0 | + \alpha_1^* \langle 1 | + \alpha_2^* \langle 2 | + \alpha_3^* \langle 3 | .$$

Page 62, line 17. The beginning of the first line of Section 2.9:

“An *observable* is a property of a physical system”

should read:

“An *observable* is an attribute of a physical system”

Page 65, line 5 from the bottom. The following proposition

“Two projectors P_i, P_j are *orthogonal* if, for every state in the Hilbert space, $\forall | \Psi_a \rangle \in \mathcal{H}_n$ ”

should read:

“Two projectors P_i, P_j are *orthogonal* if, for every state $| \Psi_a \rangle$ in the Hilbert space \mathcal{H}_n ”

Page 66, line 17. The expression:

“($\frac{i}{\hbar}$), with the momentum operator for the X component, p_x .”

should read:

“($\frac{i}{\hbar}$), with the X component of the momentum operator, p_x .”

Page 68, line 16. The sentence:

“By definition, an *observable* is any Hermitian operator whose eigenvectors form a basis.”

should read:

“By definition, an observable is a Hermitian operator whose eigenvectors form a basis; however, not any Hermitian operator whose eigenvectors form a basis represents a true observable, a true attribute of a physical system.”

Page 71, line 24.

$$\text{Prob}(\lambda_x | \Psi_a) =$$

should read:

$$\text{Prob}(\lambda_x | | \Psi_a) =$$

Page 71, line 27.

$$\text{Prob}(\lambda_x | \Psi_b) =$$

should read:

$$\text{Prob}(\lambda_x | | \Psi_b) =$$

Page 72, lines 4-8.

Delete this paragraph starting on line 4 and ending with line 8.

Page 72, line 10. In this equation the expressions:

$$\text{Prob}(\lambda_x | \Psi_a) \text{ and } \text{Prob}(\lambda_x | \Psi_b)$$

should read:

$$\text{Prob}(\lambda_x | | \Psi_a) \text{ and } \text{Prob}(\lambda_x | | \Psi_b)$$

Page 73, line 11 and 12.

$$\langle \psi_i | A | \psi_i \rangle = \sum_a \langle \psi_i | \varphi_a \rangle \langle \varphi_a | A | \psi_i \rangle = \sum_a \langle \varphi_a | A | \psi_i \rangle \langle \psi_i | \varphi_a \rangle$$

and

should read:

$$\langle \psi_i | A | \psi_i \rangle = \langle \psi_i | IA | \psi_i \rangle = \sum_a \langle \psi_i | \varphi_a \rangle \langle \varphi_a | A | \psi_i \rangle = \sum_a \langle \varphi_a | A | \psi_i \rangle \langle \psi_i | \varphi_a \rangle$$

where the identity operator $I = \sum_a | \varphi_a \rangle \langle \varphi_a |$ and

Page 74, line 20. The expression

$$\rho = \frac{3}{4} | 0 \rangle \langle 0 | + \frac{1}{4} | 1 \rangle \langle 1 | = \frac{1}{4} \begin{pmatrix} 3 & 0 \\ 0 & 1 \end{pmatrix}$$

should read:

$$\begin{aligned}\rho &= \frac{1}{2} \left(\frac{\sqrt{3}}{2} |0\rangle + \frac{1}{2} |1\rangle \right) \left(\frac{\sqrt{3}}{2} \langle 0| + \frac{1}{2} \langle 1| \right) + \frac{1}{2} \left(\frac{\sqrt{3}}{2} |0\rangle - \frac{1}{2} |1\rangle \right) \left(\frac{\sqrt{3}}{2} \langle 0| - \frac{1}{2} \langle 1| \right) \\ &= \frac{3}{4} |0\rangle \langle 0| + \frac{1}{4} |1\rangle \langle 1| = \frac{1}{4} \begin{pmatrix} 3 & 0 \\ 0 & 1 \end{pmatrix}\end{aligned}$$

Page 87, line 18.

“discovered”

should read:

“formulated”

Page 87, line 20.

“physical property”

should read:

“physical attribute”

Page 87, lines 29, 29, 31.

“property”

should read:

“attribute”

Page 88, line 5.

“value λ_a ”

should read:

“value λ_A ”

Page 88, line 8.

“system in state $|\psi\rangle$ is”

should read:

“system in state $|\psi\rangle$, corresponding to successive application of the operators B and A , is”

Page 88, line 21.

“Recall the Schwartz inequality”

should read:

“Recall the Schwarz inequality”

Page 91, line 35.

”represent properties of observable entities and the”

should read:

“represent observable attributes of physical systems and the”

Page 94, line 1.

“representing the amplitudes”

should read:

“representing the probability amplitudes”

Page 94, line 19.

“An *observable* \mathcal{O} is a property of a physical system”
should read:

“An *observable* \mathcal{O} is an attribute of a physical system”

Page 96, Problems 2.15 and 2.16.

“show that”
should read:

“ show that the vectors”

Chapter 3

Page 100, line 1 and 2.

“, $|0\rangle \mapsto |1\rangle$ and $|1\rangle \mapsto |0\rangle$.”

should read:

“, $|1\rangle \mapsto |0\rangle$ and $|0\rangle \mapsto |1\rangle$.”

Page 100, line 7.

“, $|0\rangle \mapsto i|1\rangle$ and $|1\rangle \mapsto -i|0\rangle$.”

should read:

“, $|1\rangle \mapsto -i|0\rangle$ and $|0\rangle \mapsto i|1\rangle$.”

Page 100, line before the last; equations related to σ_z .

$$= i \begin{pmatrix} \alpha_0 \\ -\alpha_1 \end{pmatrix}$$

should read:

$$= \begin{pmatrix} \alpha_0 \\ -\alpha_1 \end{pmatrix}$$

Page 104, line 14. Part of the equation on this line

$$\sin x = x - \frac{x^3}{3!} + \frac{x^5}{5!} + \dots =$$

should read:

$$\sin x = x - \frac{x^3}{3!} + \frac{x^5}{5!} - \dots =$$

Page 104, line 15. Part of the equation on this line

$$\cos x = 1 - \frac{x^2}{2!} + \frac{x^4}{4!} + \dots =$$

should read:

$$\cos x = 1 - \frac{x^2}{2!} + \frac{x^4}{4!} - \dots =$$

Page 104, line 21. Part of the equation on this line

$$\left(1 - \frac{\beta^2}{2!} + \frac{\beta^4}{4!} + \dots +$$

should read:

$$\left(1 - \frac{\beta^2}{2!} + \frac{\beta^4}{4!} - \dots +$$

Page 104, line 22. Part of the equation on this line

“second qubit can be 0”
should read:
“second qubit can be $|0\rangle$ ”

Page 112, line 30.

“or 1 with probability”
should read:
“or $|1\rangle$ with probability”

Page 113, line 9.

“possible outcomes are 0 with probability 1/2 and 1 with probability 1/2.”
should read:
“possible outcomes are $|0\rangle$ with probability 1/2 and $|1\rangle$ with probability 1/2.”

Page 113, line 14.

“outcomes are 0 with”
should read:
“outcomes are $|0\rangle$ with”

Page 113, line 15.

“and 1 with probability 1/2.”
should read
“and $|1\rangle$ with probability 1/2.”

Page 114, line 14.

“these interactions”
should read:
“these correlations”

Page 114, line 17.

“are transferred into”
should read:
“are transformed into”

Page 114, line 30.

“between the $|cat\rangle$.”
should read:
“between the cat,”

Page 114, line 38.

“information can not be copied with fidelity.”
should read:
“information can not be cloned.”

Page 117, line 29.

“what we do is preparing the qubit”
should read:
“what we do is prepare the qubit”

Page 118, line 1.

“with spin odd multiple of”
should read:
“with spin”

Page 118, lines 3-4.

“ $s = -1/2$, or an odd multiple of $s = \pm 1/2$.”
should read:
“ $s = -1/2$.”

Page 118, line 5.

“ $s = 0$, or a multiple of ± 1 .”
should read:
“ $s = 0$.”

Page 126, line 6.

“beam will split it into”
should read:
“beam will split into”

Page 127, Figure 3.19 with the caption: “The effect of a polarization filter ...”.

Last line of caption to the figure 3.19

“with probability equal to $\cos \theta$.”
should read:
“with probability amplitude equal to $\cos \theta$.”

Page 128, lines 5-6.

“It is easy to see that the eigenvalues are $e^{i\theta}$ and $e^{-i\theta}$, respectively, for the eigenstates which we call *right* and *left* polarization states.”
should read:
“We call these eigenstates *right* and *left* polarization states.”

Page 128, line 12.

“Section 3.2.”
should read:
“Section 1.8.”

Page 134, line 2.

“Hilbert space, \mathcal{H}_{2^n} defined as”
should read:
“Hilbert space, \mathcal{H}_{2^n} , defined as”

Page 135, problem 3.3.

“Show that the composition of two rotations with angles θ_1 and θ_2 is a rotation with angle $\theta_1 + \theta_2$ along the same axis”
should read:

“Show that the composition of two successive rotations about the same axis with angles θ_1 and θ_2 is a rotation with angle $\theta_1 + \theta_2$ about the same axis”

Page 136, problem 3.8.

“Augment the program in the previous assignment to compute”
should read:

“Augment the program developed for the problem 3.7 (Section 3.15) to compute”

Page 136, problem 3.8.

Move problem 3.8 from Section 3.15 to Section 4.20, page 195 after problem 4.13.

Chapter 4

Page 142. The expression

$$G^\dagger G = \begin{pmatrix} g_{11}^* g_{11} + g_{21}^* g_{12} & g_{11}^* g_{21} + g_{21}^* g_{22} \\ g_{12}^* g_{11} + g_{22}^* g_{12} & g_{12}^* g_{21} + g_{22}^* g_{22} \end{pmatrix} = 1$$

should read:

$$G^\dagger G = \begin{pmatrix} g_{11}^* g_{11} + g_{21}^* g_{21} & g_{11}^* g_{12} + g_{21}^* g_{22} \\ g_{12}^* g_{11} + g_{22}^* g_{21} & g_{12}^* g_{12} + g_{22}^* g_{22} \end{pmatrix} = 1$$

Page 149. Figure 4.5 with the caption: “(a) A classical binary circuit with two inputs x and y and two outputs x and $x \oplus y$. (b) When $y = 0$ the circuit in (a) simply replicates input x on both output lines. (c) A quantum CNOT with an arbitrary input $|\psi\rangle = \alpha_0 |0\rangle + \alpha_1 |1\rangle$; we would like it to replicate $|\psi\rangle$ on its output lines. We know its desired output state but we do not know yet what the second input should be. (d) If we select the second input to be $|0\rangle$ then the output is $\alpha_0 |00\rangle + \alpha_1 |11\rangle$, not exactly what we wished for.” should be replaced with the following figure:

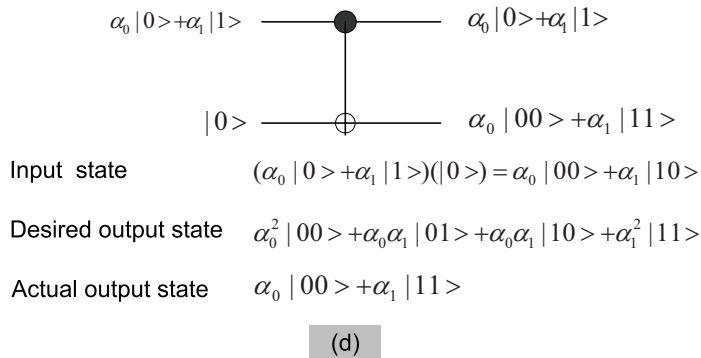
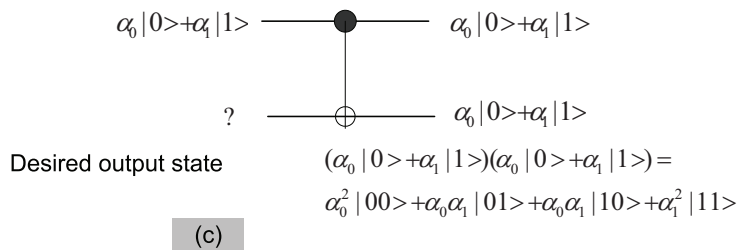
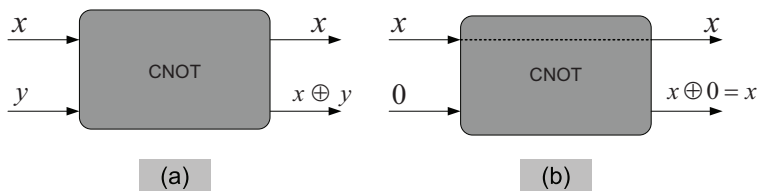

Page 152. Figure 4.6 with the caption: “ The Fredkin gate has three inputs, a , b , and control, or c ; it also has three outputs, a' , b' , and $c' = c$. (a) When $c = 0$ the inputs appear at the output, $a' = a$ and $b' = b$. (b) When $c = 1$ the inputs are swapped, $a' = b$ and $b' = a$. (c) The truth table for the Fredkin gate. (d) When $a = 0$ then $a' = bc$ and $b' = b\bar{c}$, the Fredkin gate becomes an AND gate. (e) When $a = 1$ and $b = 0$ the Fredkin gate becomes a NOT gate. ” should be replaced with the following figure:

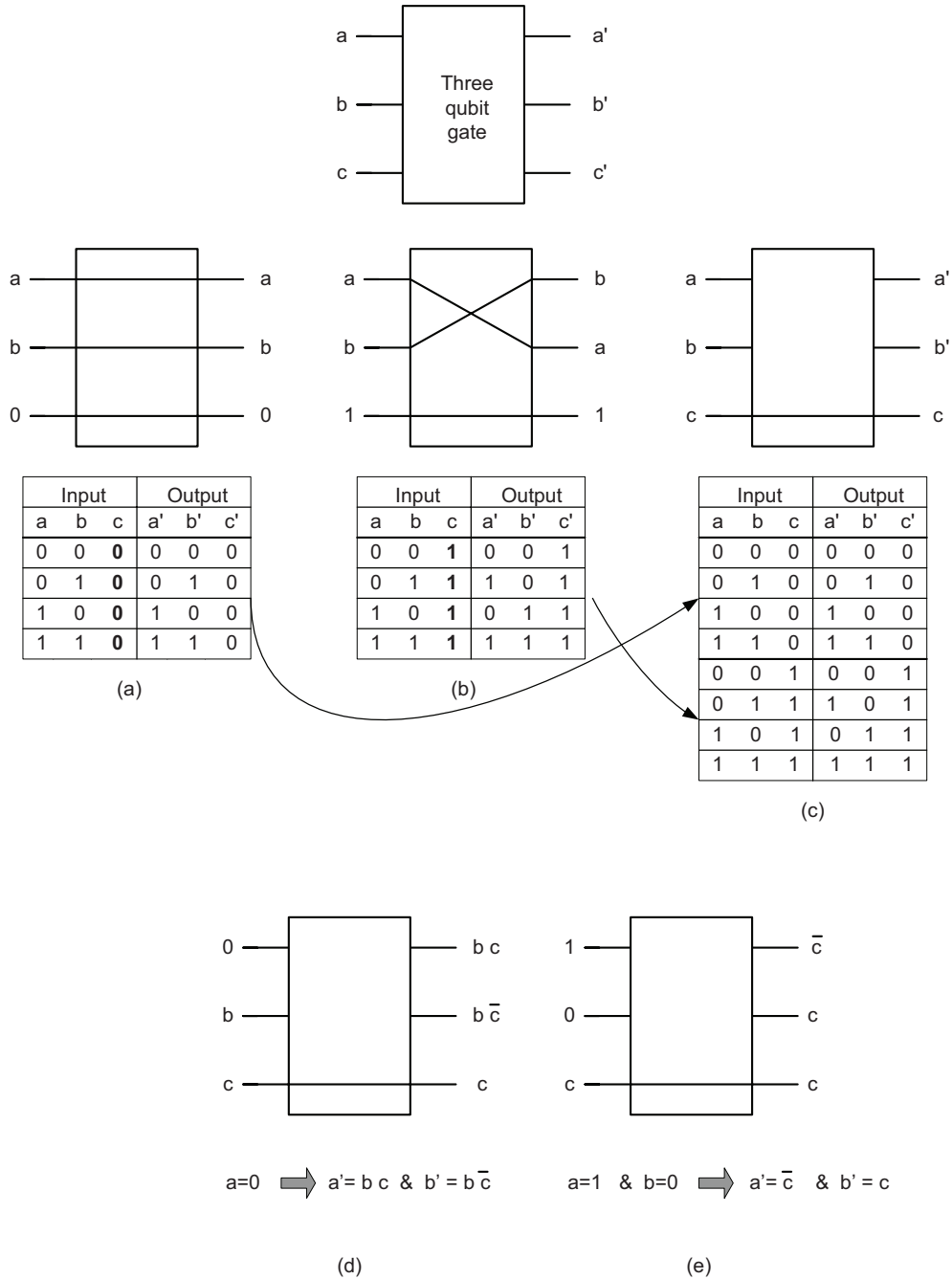

Page 162, line 21.

$$\overline{x + y} = \overline{xy} \text{ and } \overline{xy} = \overline{x} + \overline{y}$$

should read:

$$\overline{x+y} = \bar{x} \bar{y} \quad \text{and} \quad \overline{xy} = \bar{x} + \bar{y}$$

Page 165, line 5. The expression

“the phase - (S),”

should read:

“the phase, (S),”

Page 174. Figure 4.18 (b) with the caption: “(a) A generic single qubit controlled gate with matrix $U = A\sigma_x B\sigma_x C$. (b) A circuit simulating the generic single qubit controlled gate in (a)”

should be replaced with the following figure:

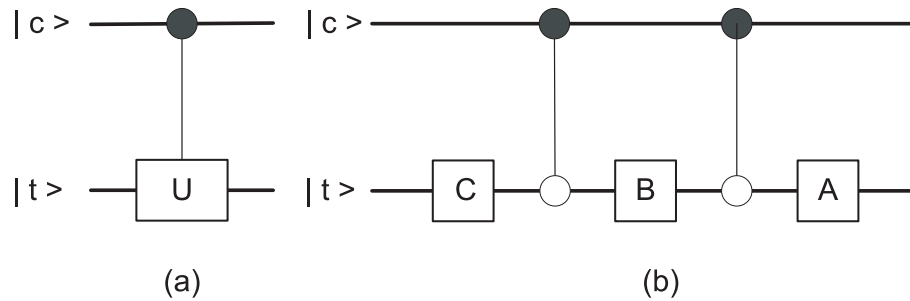

Page 175, equality on lines 10 - 12. The first term on the last line of this equality

$$\alpha_0 |c_0 c_1 \dots c_{n-2} 0\rangle +$$

should read:

$$\alpha_0 |c_0 c_1 \dots c_{n-1} 0\rangle +$$

Page 177, line 14. The expression

“Several universal family of gates can be implemented”

should read:

“Several universal gates can be implemented”

Page 177, line 23. The expression

“phase, S, T, and $\pi/8$ one-qubit gates where”

should read:

“phase, S, and $\pi/8$, T, one-qubit gates where”

Page 180. The matrix on top of the page:

$$= \begin{pmatrix} HT & O & O & O \\ O & e^{-i\pi/2} HT & O & O \\ O & O & e^{-i\pi/4} HT & O \\ O & O & O & e^{-i\pi/4} HT \end{pmatrix}.$$

should read:

$$= \begin{pmatrix} HT & O & O & O \\ O & e^{-i\pi/2}HT & O & O \\ O & O & e^{-i\pi/4}HT & O \\ O & O & O & e^{-i\pi/2}HT \end{pmatrix}.$$

Page 187, line 19.

“where u_0 and u_1 are orthonormal base vectors in \mathcal{H}_2 .”

should read:

“where $|u_0\rangle$ and $|u_1\rangle$ are orthonormal basis vectors in \mathcal{H}_2 .”

Page 187, line 22.

“see Section 3.8.”

should read:

“see Section 4.4.”

Page 191, line 29.

“A *uniform family of circuits* is a set of circuits with one circuit for each number of bits.”

should read:

“A *uniform family of circuits* is a set of circuits, $\{C_n\}$, with one circuit for each input of length n . The *uniformity condition* requires that the description of a circuit C_n should be computed in time *poly*(n) on some Turing machine.”

Page 191, line 32.

“the circuit with n input bits has at most $kf(n)^2$ elements”

should read:

“the circuit with n input bits has at most $kT(n)^2$ elements”

Page 192, line 40.

“The Toffoli gate is a universal gate and it is reversible.”

should read:

“The Toffoli gate is universal and reversible.”

Page 193, line 10.

“4. A universal family of gates can be implemented”

should read:

“4. A family of universal gates can be implemented”

Page 194, problem 4.11. The expression

$$G_n = \{0G_{n-1}, 1G_{n-1}\}$$

should be replaced with:

$$G_n = \{0G_{n-1}, 1\bar{G}_{n-1}\}$$

with \bar{G}_{n-1} being the mirror image of set G_{n-1} . This construction is illustrated in the following figure:

$$\begin{array}{c} 0 \\ 1 \end{array} \longrightarrow \begin{array}{c} 0 \\ 1 \\ 1 \\ 0 \end{array} \longrightarrow \begin{array}{c|c} 0 & 0 \\ 0 & 1 \\ 1 & 1 \\ 1 & 0 \end{array}$$

Construction of $G_2=(00,01,11,10)$
from $G_2=(0,1)$

$$\begin{array}{c} 00 \\ 01 \\ 11 \\ 10 \end{array} \longrightarrow \begin{array}{c} 00 \\ 01 \\ 11 \\ 10 \\ 10 \\ 11 \\ 01 \\ 00 \end{array} \longrightarrow \begin{array}{c|c} 000 & 000 \\ 001 & 001 \\ 011 & 011 \\ 010 & 010 \\ 110 & 110 \\ 111 & 111 \\ 101 & 101 \\ 100 & 100 \end{array}$$

Construction of
 $G_3=(000,001,011,010,110,111,101,100)$
from $G_2=(00,01,11,10)$

Chapter 5

Page 201, line 2. The term

$$= \frac{1}{2^{n/2}}(|0\rangle + |1\rangle)^n =$$

should read:

$$= \frac{1}{2^{n/2}}(|0\rangle + |1\rangle)^{\otimes n} =$$

Page 224, Footnote (6), line 2.

“or composite was posted on a Web site on August 6, 2002 [3].”

should read:

“or composite was posted on a Web site on August 6, 2002 (published in 2004) [3].”

Page 226. The equation

$$r^{k-1} + r^{k-2} + \dots + r^2 + r + 1 \neq 1 \pmod{N}$$

should read:

$$r^{k-1} + r^{k-2} + \dots + r^2 + r + 1 \neq 0 \pmod{N}.$$

Page 226. Figure 5.9 on page 226 with the caption: “Computing the order k for an integer q such that $q^k = 1 \pmod{N}$ can be represented graphically as a cycle of length $k - 1$. ” should be replaced with with the following figure:

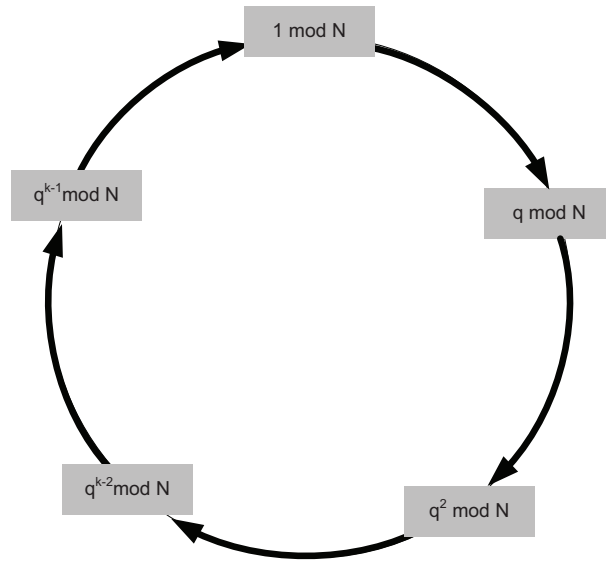

Page 226 lines 18-26. The equations should be:

$$\begin{aligned}
 \underline{k=2}: & \quad 11^2 = 121 = 5 \times 21 + 16 & \quad \mapsto 11^2 = 16 \pmod{21} \\
 \underline{k=3}: & \quad 11^3 = 11 \times 11^2 = 11 \times 16 \pmod{21} = 8 \pmod{21} & \quad \mapsto 11^3 = 8 \pmod{21} \\
 \underline{k=4}: & \quad 11^4 = 11 \times 11^3 = 11 \times 8 \pmod{21} = 4 \pmod{21} & \quad \mapsto 11^4 = 4 \pmod{21} \\
 \underline{k=5}: & \quad 11^5 = 11 \times 11^4 = 11 \times 4 \pmod{21} = 2 \pmod{21} & \quad \mapsto 11^5 = 2 \pmod{21} \\
 \underline{k=6}: & \quad 11^6 = 11 \times 11^5 = 11 \times 2 \pmod{21} = 1 \pmod{21} & \quad \mapsto 11^6 = 1 \pmod{21}
 \end{aligned}$$

Page 227. Figure 5.10 on page 227 with the caption: “Computing the order k for an integer q such that $q^k = 1 \pmod{N}$ can be represented graphically as a cycle of length $k - 1$. ” should be replaced with the following figure (to include the six powers of $11 \pmod{21}$):

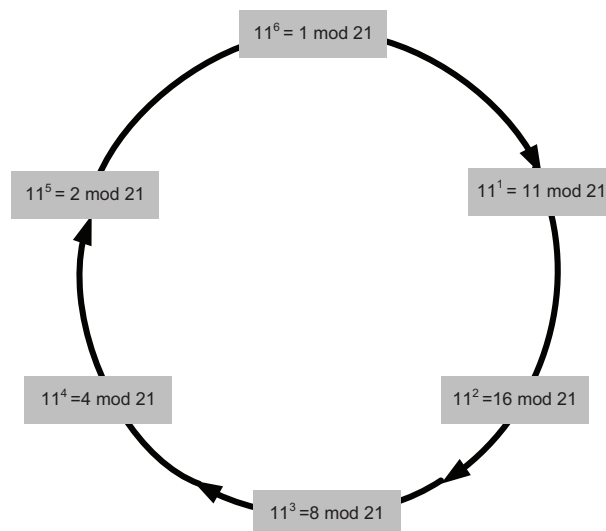

Page 227. Figure 5.11 on page 228 with the caption: “The flowchart of the factorization algorithm based upon order finding. Illustrated is the case $N = 21$ and $q = 11$ which produces 3 as a proper factor of 21. ” should be replaced with the following figure:

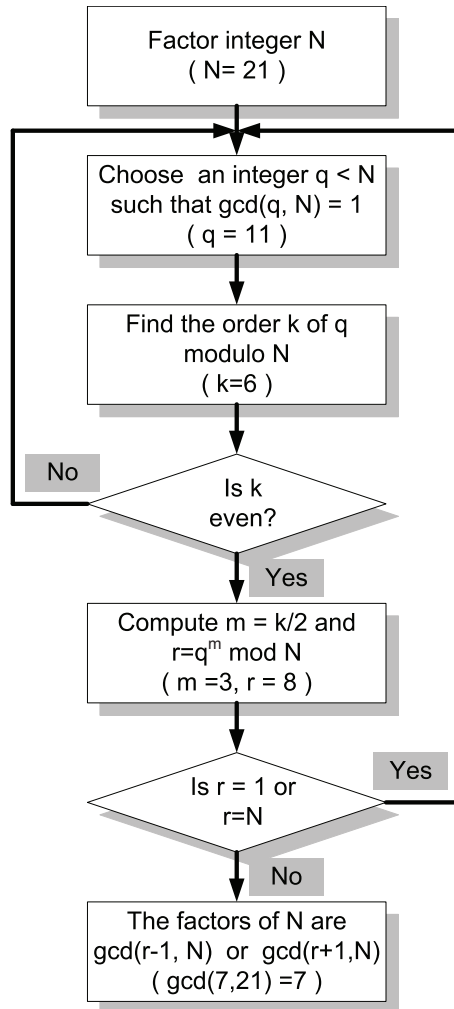

The caption should be: “The flowchart of the factorization algorithm based upon order finding. Illustrated is the case $N = 21$ and $q = 11$ which produces 7 as a proper factor of 21.”

Page 228, the pseudocode to carry out the computation should read:

```

power:= 1
for i=0 to m-1
    if (rki == 1) then
        power := power × r2i
    endif
endfor
  
```

Page 231, caption to Fig. 5.12, last line

$$|x\rangle |u\rangle \mapsto e^{(-i(2\pi/2^m)f(x))} |x\rangle |y\rangle$$

should read:

$$|x\rangle |u\rangle \mapsto e^{(-i(2\pi/2^m)f(x))} |x\rangle |u\rangle$$

Page 245, line 28.

“as the composition of the homomorphism”
should read:

“as the composition (\circ) of the homomorphism”

Page 247, line 5.

“quantum search algorithm of Grover,”
should read:

“quantum search algorithm of Grover [67, 68],”

(**Note:** [67] corresponds to {grover96} and [68] corresponds to {grover97})

Page 251, line 7. The equation under Step 3:

$$|i\rangle \mapsto (-1)^{f(j)} |j\rangle$$

should read:

$$|j\rangle \mapsto (-1)^{f(j)} |j\rangle$$

Page 252, First equation. The term on the left of the equal sign

$$2(|\psi\rangle\langle\psi| - I)$$

should read:

$$2|\psi\rangle\langle\psi| - I$$

Page 252, Second equation. The equality:

$$|\xi\rangle = 2(|\psi\rangle\langle\psi| - I)|\varphi\rangle$$

should read:

$$|\xi\rangle = (2|\psi\rangle\langle\psi| - I)|\varphi\rangle$$

Page 254, line 8.

“The reflection of $|\psi\rangle$ in L_1 ”
should read:

“The reflection of $|\psi\rangle$ about L_1 ”

Page 270, paragraph labeled 2., line 3.

“ $H \otimes I \otimes I$ and transforms the state of the qubit to $|\xi\rangle$.”
should read:

“ $H \otimes I \otimes I$ and transforms the state of the qubit to $|\zeta\rangle$.”

Page 277, line 20.

“Zeillinger”
should read:

“Zeilinger”

Page 281, last equation. The equation at the bottom of the page should read:

$$11 \mapsto G_{11} = iY \otimes I = i \begin{pmatrix} 0 & -i \\ i & 0 \end{pmatrix} \otimes \begin{pmatrix} 1 & 0 \\ 0 & 1 \end{pmatrix} = i \begin{pmatrix} 0 & 0 & -i & 0 \\ 0 & 0 & 0 & -i \\ i & 0 & 0 & 0 \\ 0 & i & 0 & 0 \end{pmatrix}$$

Chapter 6

Page 268, line 34. The formulation on line 34

“...though Bob needs to first to receive classical information regarding the result of Alice’s measurement before validating his own result.”

should read:

“...though Bob needs first to receive classical information regarding the outcome of Alice’s measurement before applying one of the transformations I, X, Z or Y to the entangled qubit in his possession (see Figure 6.2).”

Page 280, lines 6, 9, 12, 15. The formulation

“and transmits a qubit in state”

should read:

“and forces the state of the entangled pair to become:”

Page 297, line 10, 11, and 12. The expressions for the average values of the operators and the text:

$$\langle QS \rangle = \langle RS \rangle = \langle RT \rangle = \frac{1}{\sqrt{2}} \langle QT \rangle = -\frac{1}{\sqrt{2}}.$$

It follows immediately that

$$\langle QS \rangle + \langle RS \rangle + \langle RT \rangle - \langle QT \rangle = 2\sqrt{2}.$$

should read:

$$\langle QS \rangle = \langle RS \rangle = \langle RT \rangle = \frac{1}{\sqrt{2}}$$

and

$$\langle QT \rangle = -\frac{1}{\sqrt{2}}.$$

Then

$$\langle QS \rangle + \langle RS \rangle + \langle RT \rangle - \langle QT \rangle = 2\sqrt{2}.$$

Page 297, line 6. The sentences:

“The observable Q is the output of a Z gate and R the one of an X gate with Alice’s particle as input. A similar interpretation holds for Bob’s observables.”

should read

“Here Q is the outcome of a measurement of Alice’s qubit in the eigenbasis of σ_z after it has been acted upon by the Z gate; R is the outcome of a measurement of Alice’s qubit in the eigenbasis of σ_x after it has been acted upon by the X gate. In Bob’s case, S and T are the outcomes of measurements of his qubit after it has been acted upon by different combinations of Z and X gates”

Page 302, line 6 of the text. The formulation:

“the demon has to expand energy...”

should read

“the demon has to expend energy...”

Page 303, line 1 of the text. The formulation:

“is much more easier to grasp”

should read

“is much easier to grasp”

Page 313, problem 6.11. The problem should read:

“Recall from Chapter 2 that the average value of an observable A of a quantum system in state $|\psi\rangle$ is given by

$$\langle A \rangle = \langle \psi | A | \psi \rangle$$

Given a two-qubit quantum system in the entangled state

$$|\psi\rangle = \frac{|0\rangle - |1\rangle}{\sqrt{2}}$$

the first qubit is sent to Alice and the second qubit is sent to Bob. Alice measures her qubit and obtains:

$$Q = Z_1 \quad \text{and} \quad R = X_1$$

where Q is the outcome of a measurement of her qubit in the eigenbasis of σ_z after it has been acted upon by the Z gate; R is the outcome of a measurement of Alice's qubit in the eigenbasis of σ_x after it has been acted upon by the X gate.

Bob measures his qubit and obtains:

$$S = -\frac{Z_2 + X_2}{\sqrt{2}} \quad \text{and} \quad T = \frac{Z_2 - X_2}{\sqrt{2}}$$

where S and T are the outcomes of measurements of his qubit after it has been acted upon by different combinations of Z and X gates. Show that

$$\langle QS \rangle = \langle RS \rangle = \langle RT \rangle = \frac{1}{\sqrt{2}}$$

and

$$\langle QT \rangle = -\frac{1}{\sqrt{2}}.$$

Appendix A

Page 318, line 1.

“The “conjugation” has”

should read:

“The “complex conjugation” has”

Bibliography

Page 346, the entry 3. ({agrawal02})

“<http://www.cse.iitk.ac.in>, 2002.”

should read:

“http://www.cse.iitk.ac.in/users/manindra/algebra/primalty_original.pdf, 2002. Published in *Annals of Mathematics*, 160(2):781 - 793, 2004.”

Page 347, the entry 20. ({bernstein97}), on line 1

“SIAM J. Computing”

should read:

“SIAM J. on Computing”

Page 347, the entry 21. ({berthiaume92}), on line 2

“Physics of Computation”

should read:

“Physics and Computation”

Glossary

Page 362. The entry

“entscheidungsproblem”

should read:

“Entscheidungsproblem ”

Pages 375, Entry

“Schwartz inequality”

should read

“Schwarz inequality”

Index

Pages 385, Entry

“Schwartz inequality”

should read

“Schwarz inequality”