

UCF



Stands For Opportunity

CDA6530: Performance Models of Computers and Networks

***Chapter 1: Review of Practical
Probability***

Probability Definition

- ❑ Sample Space (S) which is a collection of objects (all possible scenarios or values). Each object is a sample point.
 - ❑ Set of all persons in a room
 - ❑ $\{1,2,\dots,6\}$ sides of a dice
 - ❑ $\{(1,1), (1,2), (1,3)\dots (2,2), (2,3)\dots\}$ for throwing two dices and counting each dice's number
 - ❑ $\{2,3,\dots,12\}$ for two dices and counting overall number
 - ❑ $\{0,1\}$ for shooter results
 - ❑ $(0,1)$ real number
- ❑ An event E is a set of sample points
 - ❑ Event $E \subseteq S$

Probability Definition

- **Probability P defined on events:**
 - $0 \leq P(E) \leq 1$
 - If $E = \phi$ $P(E) = 0$; If $E = S$ $P(E) = 1$
 - If events A and B are mutually exclusive,
 $P(A \cup B) = P(A) + P(B)$
- **Classical Probability P :**
 - $P(E) = \frac{\text{\# of sample points in } E}{\text{\# of sample points in } S}$

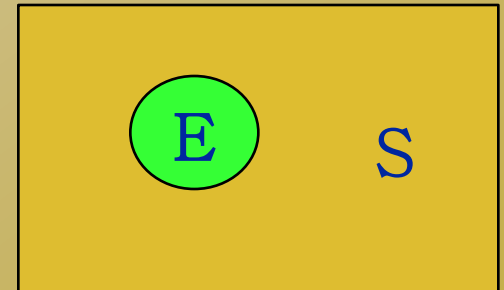

-
- A^c is the complement of event A:
 - $A^c = \{w: w \text{ not in } A\}$
 - $P(A^c) = 1 - P(A)$
 - Union: $A \cup B = \{w: w \text{ in } A \text{ or } B \text{ or both}\}$
 - Intersection: $A \cap B = \{w: w \text{ in } A \text{ and } B\}$
 - $P(A \cup B) = P(A) + P(B) - P(A \cap B)$
 - How to prove it based on probability definition?
 - For simplicity, define $P(AB) = P(A \cap B)$

Conditional Probability

- **Meaning of $P(A|B)$**
 - Given that event B has happened, what is the probability that event A also happens?
 - $P(A|B) = P(AB)/P(B)$
 - Physical meaning? (hint: use graph)
- **Constraint sample space (scale up)**

$$P(s|B) = \begin{cases} P(s)/P(B) & \text{if } s \in B \\ 0, & \text{otherwise} \end{cases}$$

Example of Conditional Probability

- ❑ A box with 5000 chips, 1000 from company X, other from Y. 10% from X is defective, 5% from Y is defective.
- ❑ $A = \text{"chip is from X"}$, $B = \text{"chip is defective"}$
- ❑ Questions:
 - ❑ Sample space?
 - ❑ $P(B) = ?$
 - ❑ $P(A \cap B) = P(\text{chip made by X and it is defective})$
 - ❑ $P(A \cap B) = ?$
 - ❑ $P(A|B) = ?$

 - ❑ $P(A|B) ? P(AB)/P(B)$

Statistical Independent (S.I.)

- If A and B are S.I., then $P(AB) = P(A)P(B)$
 - $P(A|B) = P(AB)/P(B) = P(A)$
- Theory of total probability
 - $P(A) = \sum_{j=1}^n P(A|B_j)P(B_j)$
where $\{B_j\}$ is a set of mutually exclusive exhaustive events, and $B_1 \cup B_2 \cup \dots \cup B_n = S$
 - Let's derive it for $n=2$:
 - $A = AB \cup AB^c$ mutually exclusive
 - $P(A) = P(AB) + P(AB^c)$
 $= P(A|B)P(B) + P(A|B^c)P(B^c)$

Example of Law of Total Probability

- A man shoots a target. When sunny day, he has 0.8 prob. to hit the target; when raining day, he has 0.4 prob. to hit. The weather has 0.7 prob. to be sunny, and 0.3 prob. to be raining.
- The man shoots today. What is the chance that he hits the target today?

Another Interesting Example Using Law of Total Probability

- ❑ In a gamble game, there are three cards, two are blank and one has sign. They are folded and put on table, and your task is to pick the signed card. First, you pick one card. Then, the casino player will remove one blank card from the remaining two. Now you have the option to change your pick, or stick to your original pick. Which option should you take? What is the probability of each option?

Application of Statistical Independent (S.I.)

- R_i : reliability of component i
 - $R_i = P(\text{component } i \text{ works normally})$

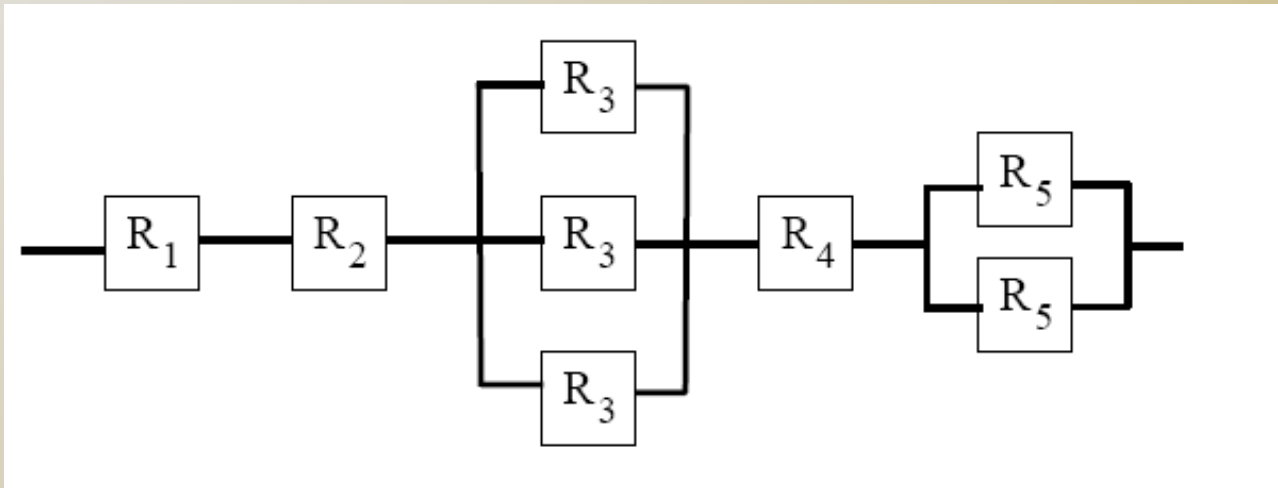

$$R_{sys} = R_1 \cdot R_2 \cdot [1 - (1 - R_3)^3] \cdot R_4 \cdot [1 - (1 - R_5)^2]$$

Simple Derivation of Bayes' Formula

□ Bayes:

$$\begin{aligned} P(A|B) &= \frac{P(B|A)P(A)}{P(B)} \\ &= \frac{P(B|A)P(A)}{P(B|A)P(A) + P(B|A^c)P(A^c)} \end{aligned}$$

□ Conditional prob.:

$$P(A|B) = P(AB)/P(B)$$

$$P(B|A) = P(AB)/P(A)$$

Bayes' Theorem

- Calculate posterior prob. given observation
 - Events $\{F_1, F_2, \dots, F_n\}$ are mutually exclusive
 - $\bigcup_{i=1}^n F_i = S$
 - E is an observable event
 - $P(E|F_i), P(F_i)$ are known
- As E happens, which F_k is mostly likely to have happened?

$$P(F_k|E) = \frac{P(E|F_k)P(F_k)}{\sum_{i=1}^n P(E|F_i)P(F_i)}$$

- Law of total prob. $P(E) = \sum_{i=1}^n P(E|F_i)P(F_i)$

Example 1

- A man shoots a target. When sunny day, he has 0.8 prob. to hit the target; when raining day, he has 0.4 prob. to hit. The weather has 0.7 prob. to be sunny, and 0.3 prob. to be raining.
- Q: the man misses the target today, what is prob. that today is sunny? Raining?
 - The raining prob. is enlarged given the shooting result

Concept Difference

- ❑ If Event A and B are statistical independent, are they mutually exclusive?

- ❑ If Event A and B are mutually exclusive, are they statistical independent?

Example 2

- A blood test is 95% accurate (detects a sick person as sick), but has 1% false positive (detects a healthy person as sick). We know 0.5% population are sick.
- Q: if a person is tested positive, what is the prob. she is really sick?
- **Step 1: Model**
- **Step 2: Analysis**

- Testing positive only means suspicious, not really sick, although testing has only 1% false positive.
 - Worse performance when $P(D)$ decreases.
 - Example: whether to conduct breast cancer (colon cancer) testing in younger age?

Bayes Application ----

Naïve Bayes Classification

- **Email: Spam (S) or non-spam (H)**
 - From training data, we know: $P(w_i|S)$, $P(w_i|H)$
 - w_i : keyword i in an email
 - **Define E: the set of keywords contained in an email**
 - For any email, $P(E|S)=\prod P(w_i|S)$, $P(E|H)=\prod P(w_i|H)$
 - Implicit assumption that keywords are independent
 - **Q: for an email, prob. to be a spam(ham)?**
 - Model for Question: $P(S|E)$, $P(H|E)$

$$P(S|E) = \frac{P(E|S)P(S)}{P(E)}$$

$$P(H|E) = \frac{P(E|H)P(H)}{P(E)}$$

Reference: Naive Bayes classifier

http://en.wikipedia.org/wiki/Naive_Bayes_classifier



Naïve Bayes Classification – Spam Detection Example

- Suppose the keyword set is
 - {dollar, cheap, free, prize, ...}
 - From training data, we know that a spam email has prob. 0.2 to contain 'dollar', 0.5 to contain 'cheap',; a normal email has prob. 0.05 to contain 'dollar', 0.01 to contain 'cheap',
 - Among all received emails by our email server, 10% are spam and 90% are normal emails
- Now an incoming email contains keyword {dollar, cheap}, what is the prob. it is spam? Normal email?

- ❑ Questions?