

Homework #1 – 100 points -

Due: Friday February 21, 2014 by 11:59 pm NO LATE ASSIGNMENTS ACCEPTED

Answer each of the following questions completely. Make sure that your answers are **neatly written and very readable**. Points will be deducted if your assignment is not presented in a neat format. Submit your assignment via WebCourses.

1. (25 points total)

Given the E-R diagram (ERD) shown below, provide answers for (a)-(c).

- (a) (10 points) Write the explicit cardinalities (i.e., UML style) indicated by the crow's foot notation used in the ERD.
- (b) (10 points) List 5 of the business rules reflected by this ERD.
- (c) (5 points) If we assume that DEPENDENT is a weak entity, describe the composition of its primary key.

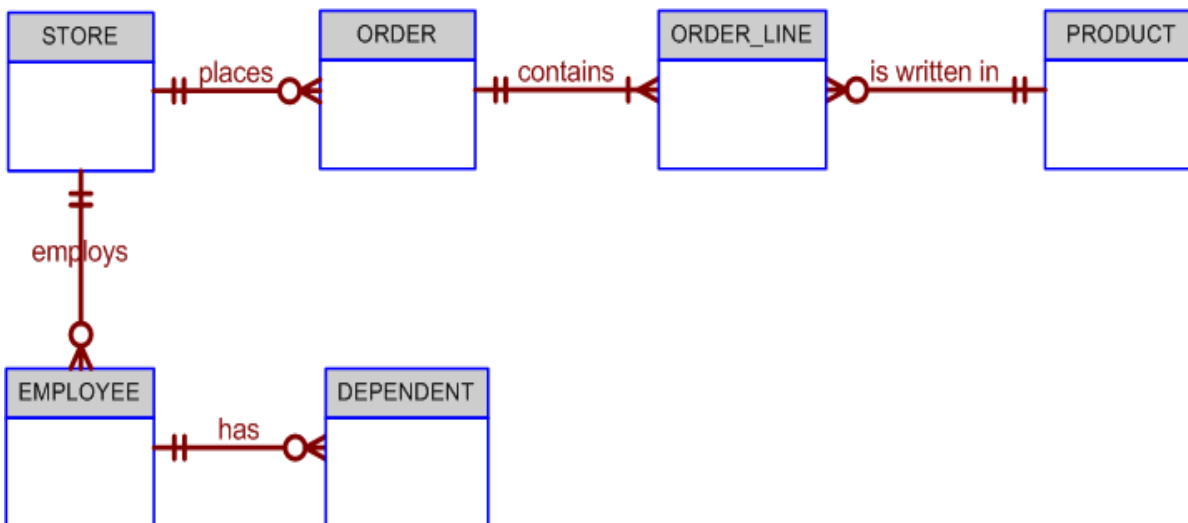

2. (15 points)

Construct a Crow's foot ERD for the scenario described by the following set of business rules. . Write all appropriate connectivities and cardinalities in the ERD.

Hot Water (HW) is a small start-up company that sells spas. HW does not carry any stock. A few spas are set up in a simple warehouse so customers can see some of the models available, but any products sold must be ordered at the time of the sale.

- HW can get spas from several different manufacturers.
- Each manufacturer produces one or more different brands of spas.
- Each and every brand is produced by only one manufacturer.
- Every brand has one or more models.
- Every model is produced as part of a brand. For example, Iguana Bay Spas is a manufacturer that produces Big Blue Iguana spas, a premium-level brand, and Lazy Lizard spas, an entry-level brand. The Big Blue Iguana brand offers several models, including the BBI-6, an 81-jet spa with two 6-hp motors, and the BBI-10, a 102-jet spa with three 6-hp motors.
- Every manufacturer is identified by a manufacturer code. The company name, address, area code, phone number, and account number are kept in the system for every manufacturer.
- For each brand, the brand name and brand level (premium, mid-level, or entry-level) are kept in the system.
- For each model, the model number, number of jets, number of motors, number of horsepower per motor, suggested retail price, HW retail price, dry weight, water capacity, and seating capacity must be kept in the system.

3. (25 points)

(a) Create a Crow's foot ERD that correctly depicts the following requirements:

- An INVOICE is written by a SALESREP. Each sales representative can write many invoices, but each invoice is written by a single sales representative.
- The INVOICE is written for a single CUSTOMER. However, each customer can have many invoices.
- An INVOICE can include many detail lines (LINE), each of which describes one product bought by the customer.
- The product information is stored in a PRODUCT entity.
- The product's vendor information is found in a VENDOR entity

The ERD must reflect business rules that you are free to define (within reason). Make sure that your ERD reflects the conditions you require. Finally, make sure that you include the attributes that would permit the model to be successfully implemented.

(b) Describe how your ERD might change depending on the assumptions you made in your business rules.

4. (25 points)

The FlyRight Aircraft Maintenance (FRAM) division of the FlyRight Company (FRC) performs all maintenance for FRC's aircraft. Assume the following business rules reflect how FRAM goes about its business:

- All mechanics are FRC employees. Not all employees are mechanics.
- Some mechanics are specialized in engine (EN) maintenance. Some mechanics are specialized in airframe (AF) maintenance. Some mechanics are specialized in avionics (AV) maintenance. (Avionics are the electronic components of an aircraft that are used in communication and navigation.) All mechanics take periodic refresher courses to stay current in their areas of expertise. FRC tracks all course taken by each mechanic—date, course type, certification (Y/N), and performance.
- FRC keeps a history of the employment of all mechanics. The history includes the date hired, date promoted, date terminated, and so on. (*Note:* The “and so on” component is, of course, not a real-world requirement. Instead, it has been used here to limit the number of attributes you will show in your design.)

Given those requirements, create a Crow's Foot ERD that accurately depicts this scenario.